

M-P401S/M-P406S

PUSH BAR PANIC DEVICE



M-P401S



M-P406S
(Vertical Locking Device)

Technical Specifications

Model	M-P401S	M-P406S
Material	Stainless steel 304 with stain finish	
Standard	ANSI/BHMA	
Lock point	1	2
Touch bar	Half-length, 500 mm	
Total length	1045 mm	
Door type	Timber and Metal door	
Anti-thrust latch	19mm (fire rated model)	
Stile width	41 mm	
Door thickness	35-50 mm	
Max door weight	200 kgs	
Dogging device	Allen Key	
Door width	650-1190 mm	
Door Height	N/A	2133mm

Dimension

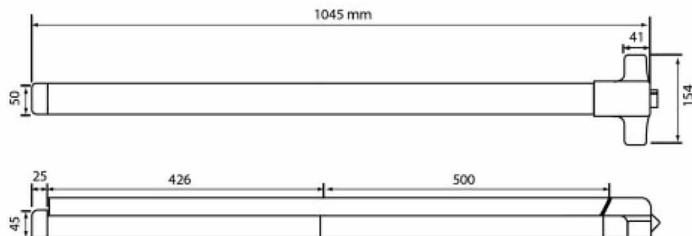

M-P401S

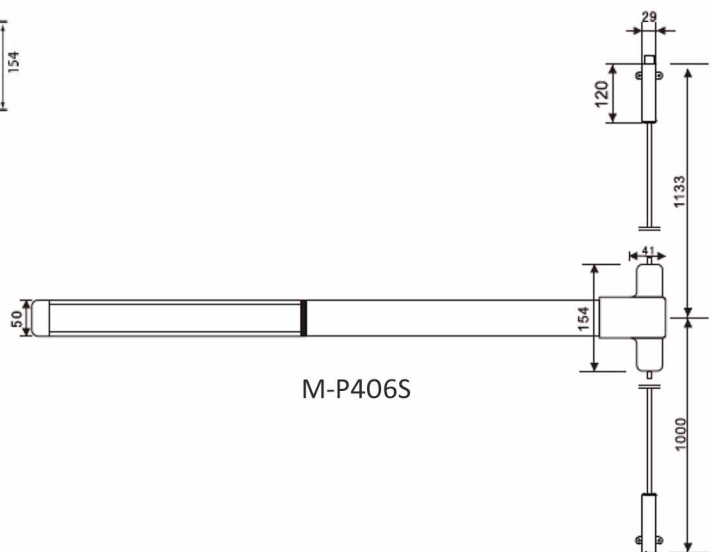

M-P406S

M-P401S - The single leaf door combination of the UL list panic device

1. M-P401S + M-A004S



2. M-P401S + M-A008S



Installation

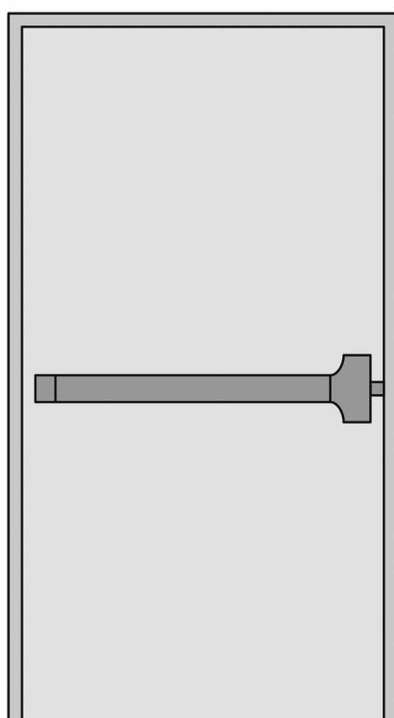

Function :	Classroom	Store Room	Fire rated steel / timber Door	Exit door, etc.
Apply to door weight:				Up to 200 kgs
Apply to Max Door width				650 – 1,000 mm
Handed:				Non – Handed

M-P406S - The single leaf door combination of the UL list panic device

1. M-P406S + M-A004S



2. M-P406S + M-A008S



Installation

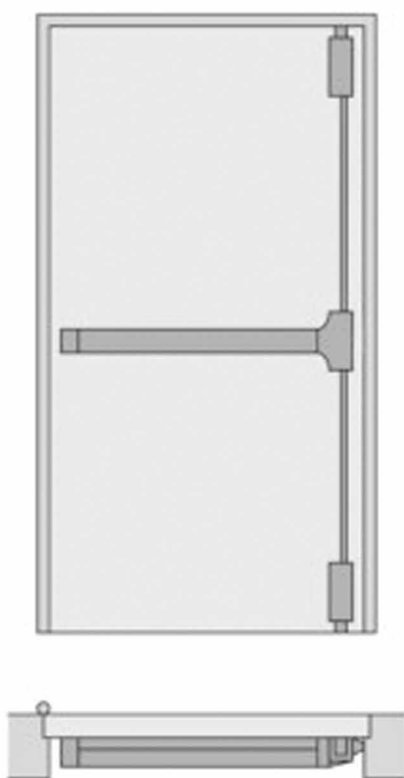

Function :	Classroom	Store Room	Fire rated steel / timber Door	Exit door, etc.
Apply to door weight:	Up to 200 kgs			
Apply to Max Door width	650 – 1,000 mm			
Apply to door height:	Standard 2,133 mm			
Handed:	Non – Handed			